

ASSEMBLY INSTRUCTIONS FOR SYSTEMS ROLLING SCREEN DOOR

1. Remove panel end of run cap.
2. Remove interlock from glide housing and save the 1/4-20 hex head bolts.
3. Install bottom brace (46-2490) using 1/4-20 x 1/2" hex head bolt (DZ-12-0007) with locking nut (202224) –

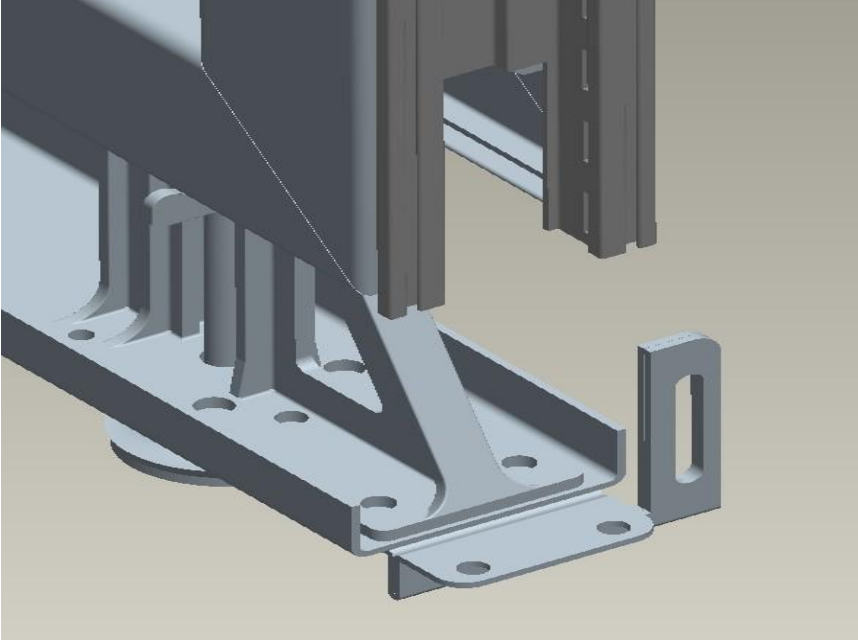

4. Install bottom door bracket (46-2491) using the second slot up from the bottom of trim rail to slide the bottom leg of the bracket through. If using the ERP bracket (46-2491-ERP) then the mounting location would remain the same. Long leg of bracket should be running vertical downward along the panel. Ensure the bracket is fully seated into the trim rail. –

One open slot

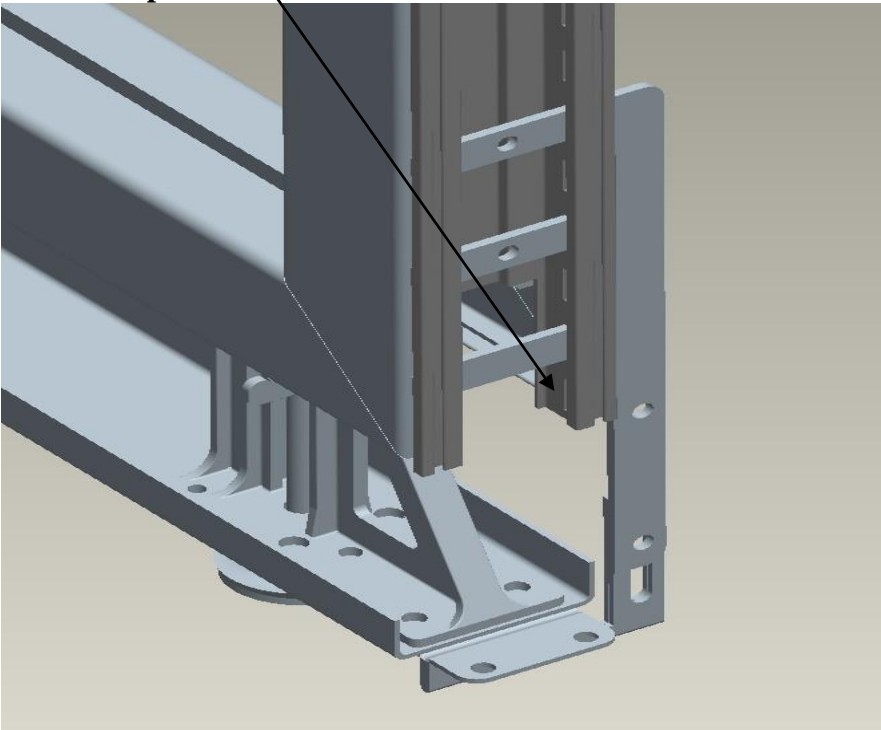

5. Install top door bracket (46-2489) locating the top of the bracket through the second slot from the top. Short leg of bracket should be towards top of panel. Ensure the bracket is fully seated into the trim rail. –

One open slot

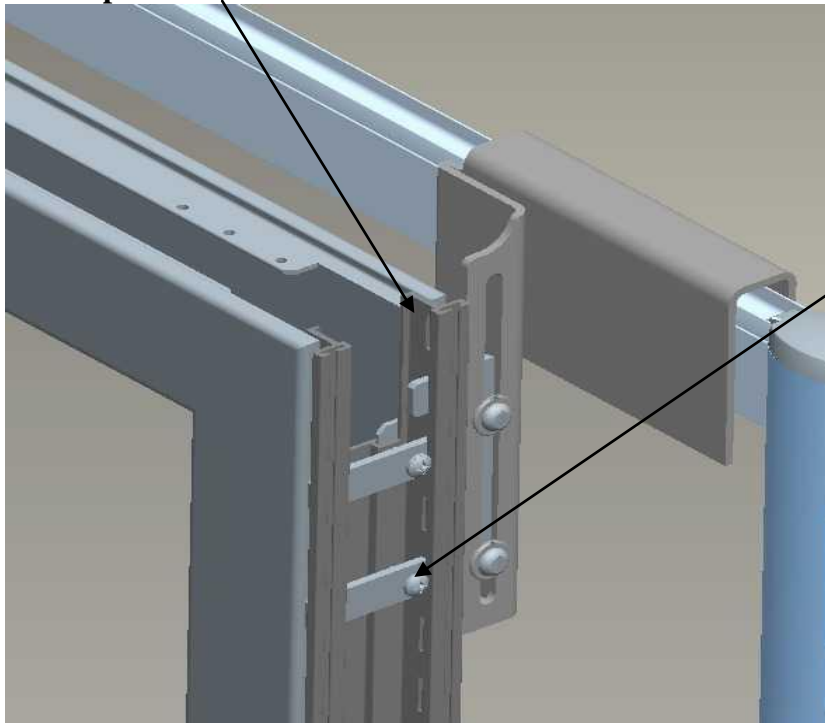

Install self drilling screws 20203 until they contact the bracket – **DO NOT OVER TIGHTEN**

6. Install the bottom Channel Bracket (46-2475-1 or 2) with the U-Channel extending into the door opening. The bottom of the Channel Bracket is initially set at 1/2" up from the floor and attached to the bottom bracket (46-2491) and bottom brace (46-2490) using the 1/4-20 x 3/4" Button Head Machine Screws (DZ-12-0007) and 1/4-20 Self Locking Nuts (202224) –

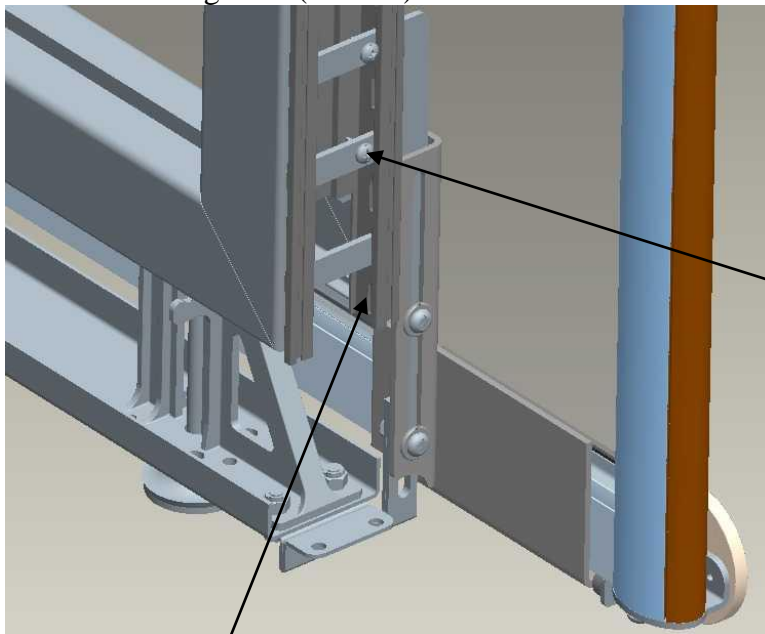

Install self drilling screws 20203 until they contact the bracket – **DO NOT OVER TIGHTEN**

One open slot

7. Attach the top and bottom panel brackets to the trim rail using the #10 x 1-1/4" self drilling screws (2.20206). **Do not over-tighten.**
8. The wheel assembly (46-2485-1 or 2) is attached to the vertical frame members of the door using the 1/4-20 x 1/2" machine screws (DZ-12-0007). Attach the wheel

assembly with wheels facing away from the panel and the wheel mounted on the inner most 10-24 tapped holes in the bracket.

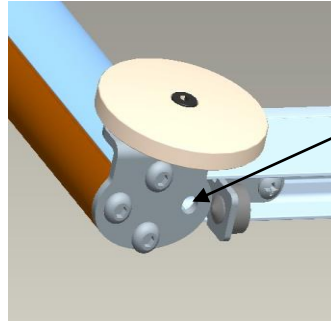

No bolt in this location
on either side of door

9. Once the wheel assemblies are installed on the door the alignment can be checked by rolling the door down the aisle. If the door tracks straight then the wheel assemblies are aligned correctly.
10. Place the door into the bottom Channel Bracket (46-2475-1 or 2). Place the top Channel Bracket (46-2475-1 or 2) over the door and install the top screws and locking nuts loosely in place through the holes of the door bracket.
11. Roll the door into the closed position not to exceed 1" beyond the opposing end of run. This will ensure customer has door handle access from the inside of the cubicle. On the panel side of the bottom Channel Bracket (46-2475-1 or 2) lightly mark the location for the door stop. –

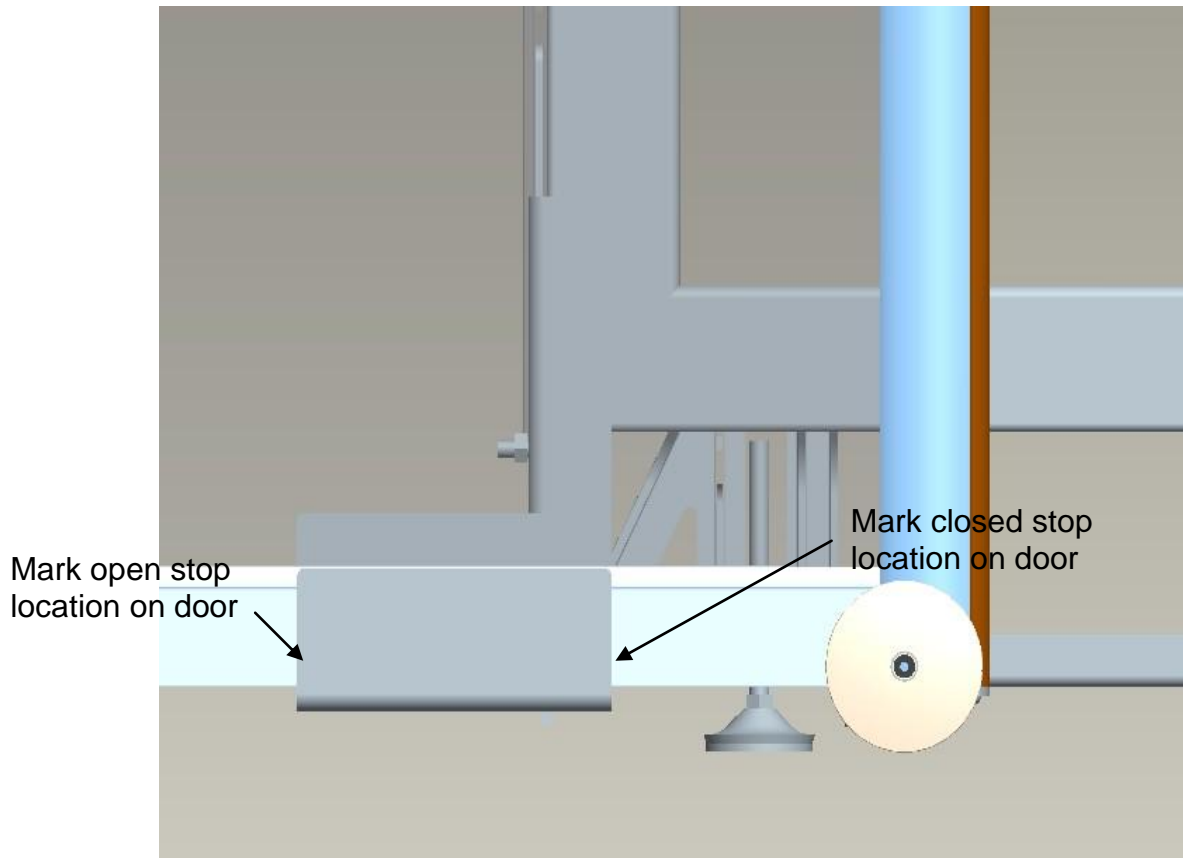

12. Open the door and mark the location of the other stop, ensuring an opening of at least 32" for any ADA requirements, on the door opening side of the bottom Channel Bracket (46-2475-1 or 2). Care should be taken if door is opening into area of another rolling door so they do not exceed travel of each other.
13. With the door removed, the stops can be located using the #10 x 5/8" self drilling screws (20203) with the rubber stop (46-2487) facing towards the center of the door panel.

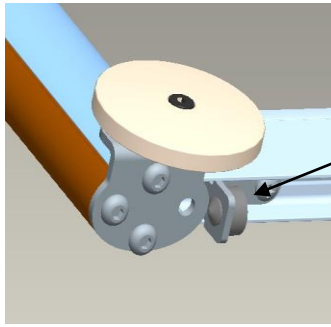

Door flipped upside down to show proper orientation of Stop Bracket Assembly.

14. Tighten the bolt going through the top channel bracket. Using a straight edge, place the straight edge along the outside of the bottom Channel Bracket and make sure the bracket is running parallel with the panel. Adjust bracket if necessary and repeat procedure for the top channel bracket.

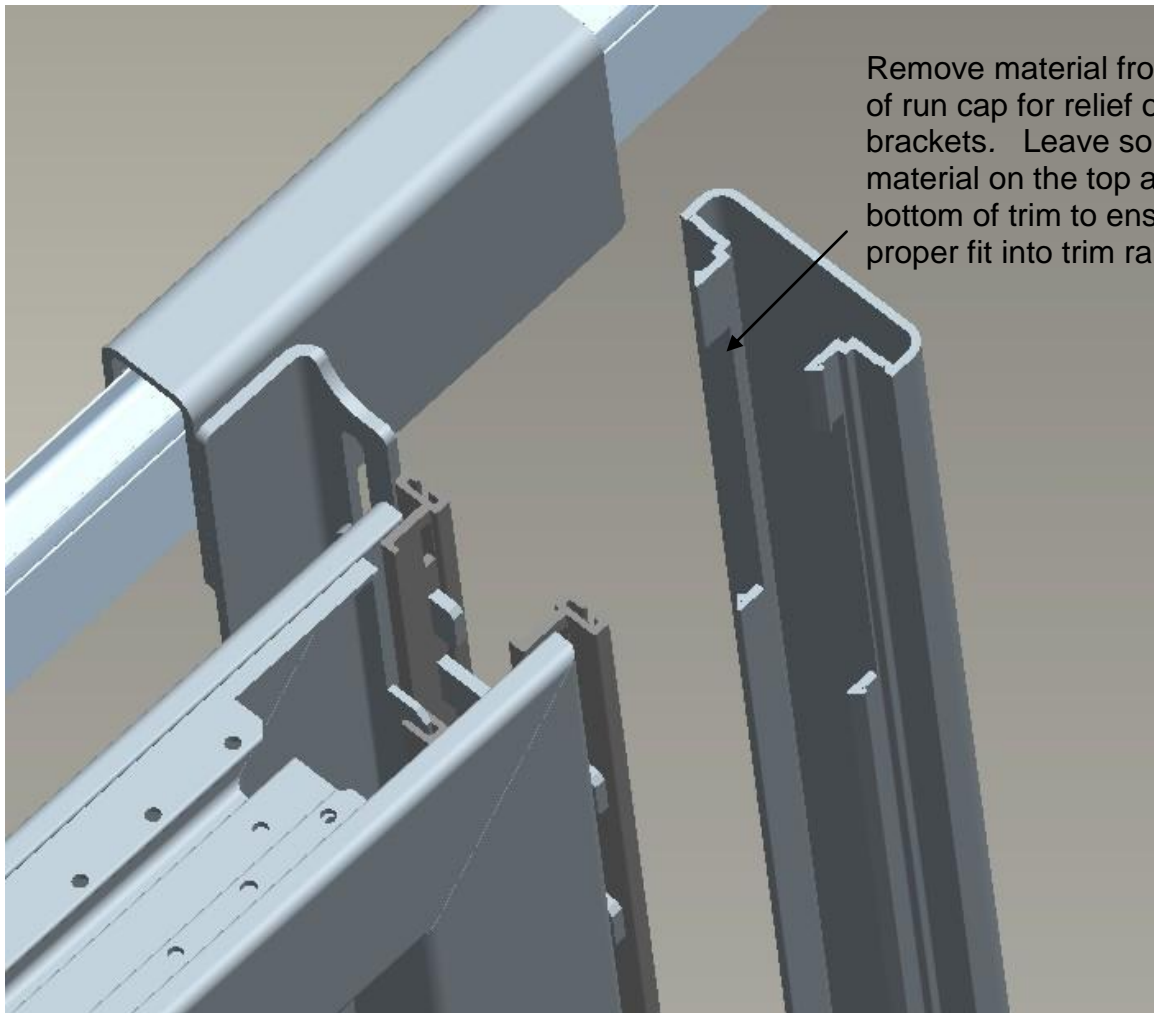

15. Loosen the bottom bolt through the top channel bracket. Lift the top bracket and set the door back in place. Raise the top bracket $\frac{3}{16}$ " above the top of the door and lightly tighten one of the bracket bolts. Roll the door open and closed and monitor this gap. Gap should be set when this clearance is at its least.
16. Remove material from panel end of run cap that will interfere with the top and bottom panel brackets and install end of run cap.

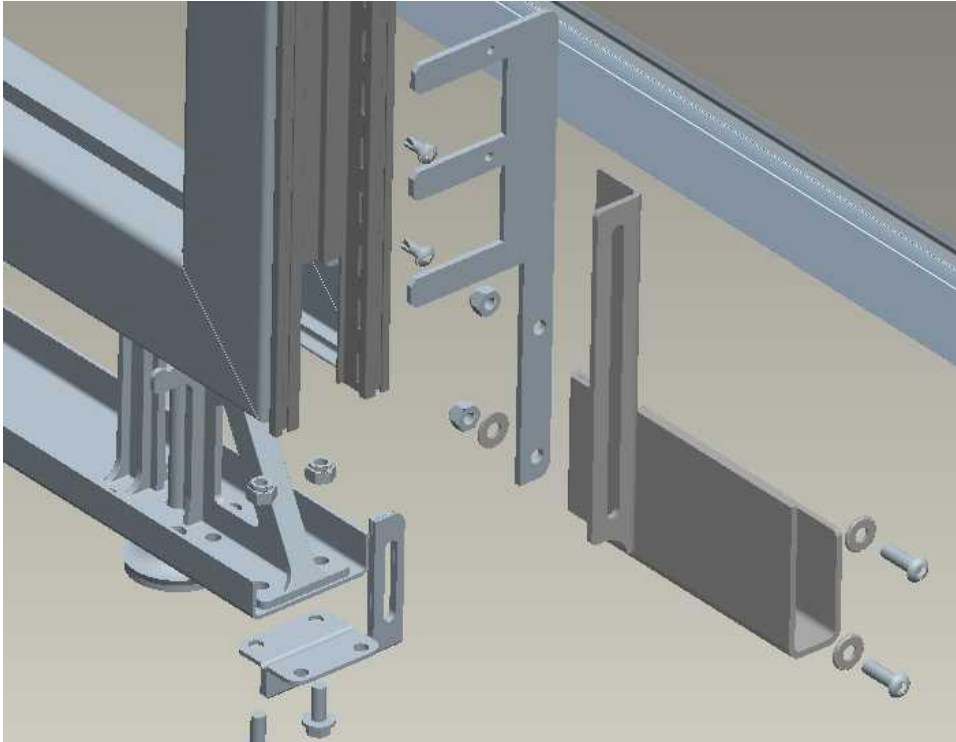

EXPLODED VIEW OF BOTTOM CHANNEL ASSEMBLY

PARTS LIST

PART #	DESCRIPTION	QUANTITY
20203	MACHINE SCREW, 10-24 x 3/8	6
46.2485.1	ASSEMBLY, WHEEL	1
46.2485.2	ASSEMBLY, WHEEL	1
46.2475.1	ASSM, CHANNEL BRACKET	1
46.2475.2	ASSM, CHANNEL BRACKET	1
20224	1/4-20 SELF LOCKING NUT	6
12.0273	WASHER, 1/4, ZINC	5
2.20054	MACHINE SCREW, 1/4-20 X .75	4
DZ.12.0007	MACHINE SCREW, 1/4-20 X .50	6
46.2488	ASSEMBLY, STOP	2
46.2489	BRACKET, UPPER DOOR	1
46.2491	BRACKET, LOWER DOOR	1
46.2491.ERP	BRACKET, ERP DOOR	1(ERP)
46.2490	BRACE, SLIDING DOOR	1
46.5257.48	HORIZONTAL EXTRUSION	2
46.5256.66.SD	VERTICAL EXTRUSION	2
46.5137.4866SD	PLASTIC CORE, SCREEN	1
46.5261	CAP, SCREEN CORNER	2
46.2493	DOOR HANDLE	1
20112	SCREW, ROBERTSON PH. 10-12 X 1 1/2	8